

PRESSURE REDUCING VALVE

Model: UL-PRV



Pressure Rating

- UL-Listed 3 - 8" : 300 psi (21 bar)
- Max. for Class#300: 400 psi (28 bar)
- Setting range: 30 - 100 psi (2 - 7 bar)

Advantage

- Piston Type Design
- Accurate Pressure Control
- No Controller Conduit
- Compact Size
- Easy to Install

Typical Applications

- House station Feeds
- Sprinkler systems with over pressure
- Deluge system with over pressure
- Foam system
- Fire hydrant water supply

Performance characteristics :

- * When inlet pressure is lower than 10psi, the main valve cannot be opened and water will go through the flow path to outlet. (Very little flow at outlet)
- * When inlet pressure is between 10 ~ 30psi, the static outlet pressure will be the same as inlet pressure.
- * When inlet pressure is higher than 30psi, the static outlet pressure will be the same as set pressure.
- * When outlet pressure is higher than inlet pressure, water will go back through the flow path to inlet. (Very little flow)

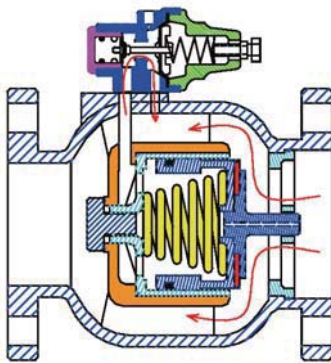

The valve open state

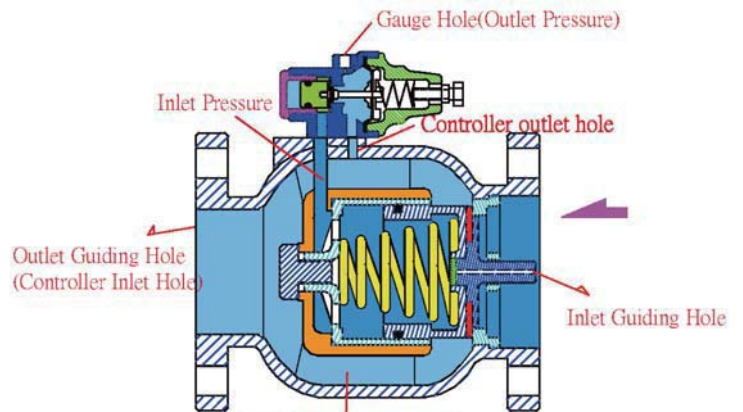

The valve close state

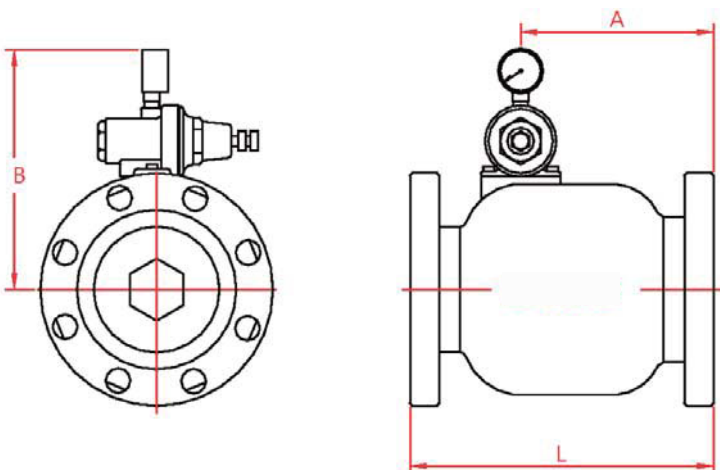

Item No.	Size	A(mm)	B(mm)	L(mm)	Weight(kg)	Max. Flow(GPM)
UL-PRV-80	3"	152	205	240	24	400
UL-PRV-100	4"	174	220	270	37	600
UL-PRV-150	6"	208	255	335	63	2000
UL-PRV-200	8"	296	295	450	112	3200

